

24 HOURS ONLINE SERVICE

400-6645-658

www.dicolor.cn

[more](#)

Dicolor

The Top Global Visual Technology Solutions Provider



Shenzhen Dicolor Optoelectronics Co., Ltd

Address: No.13 Huiye Road, Tangjia Community, Fenghuang Street,
Guangming District, Shenzhen, China

Tel: +86-755-32901555 Fax: -86-755-29604042

Website: www.dicolor.cn

SHENZHEN DICOLOR OPTOELECTRONICS CO., LTD

Display Technology Creates A Better Life

CONTENTS

Company Profile	03
History	05
International Marketing Network	07
Domestic Marketing Network	08
Honors & Qualifications	09
Core Technology	11
Quality Control	12
Products Center	13
Dicolor Best Cases	30

**COMPANY
PROFILE**



Dicolor, the top global visual technology solutions provider, has been adhering to technological innovation since its establishment 15 years ago. We have industry's leading D-COB technology independently developed by ourselves, and the world's top three stage-art performing market share, and more than 210 patents. Dicolor has won many domestic and foreign awards such as the German Red Dot Design Award and the Japanese Good Design.

Dicolor takes tage & event display, commercial display and Melink conference all-in-one as the market direction, and goes hand in hand. Products are widely used in stage leasing, broadcast media, sports, exhibitions, transportation, education, security, conferences and other fields. Dicolor always adhere to the quality concept of "Brand is based on quality", and strive to be the top one of led display industry.

Dicolor commercial group mainly focuses on ultra-high-definition small-pitch series displays and smart commercial display fixed-mounted series displays, based on the concept of "intelligent display links everything", focusing on making the display more spiritual by technology, and providing customers with real intelligent displays.

.....

2006
Established

9000m²
Guangming Headquarters

21000m²
Dongguan Production Base



COMPANY HISTORY

2006

Dicolor was founded in Shenzhen with registered capital of 500,000RMB.

2007

2007

Successfully exported 500m² screens for the Ethiopian Millennium 2000.

2008

Dicolor has become the top 20 of LED display industry; Dicolor P16mm display supported the Winter Universiade.

2009

Moved to new factory which covers 10,000m² and registered capital increased to 10 million RMB; Dicolor LED display showed in Singapore Formula 1 racing.

2010

The only one LED display company with EN12966 certification in China; Products supported the 16th Asian Games;

2011

Launched the world's first MBI5035 energy-saving display; Launched die-casting aluminum cabinet and started a new era of stage screens.

2012

Established branch office in 5 provinces; Registered capital increased to 40 million RMB; German subsidiary was founded.

2013

Launched S series for fine pixel pitch, which was applied in French National Television; Got prize of "The industry's fast growth company".

2014

Moved to new factory and office, which covers 20000m²; Established subsidiary of "Youai Technology", concentrating on traffic screen.

2015

Launched 10 million stock owned plan for employees;

2016

Launched X-Plus Series for HD rental; 1000m² screens were installed in Macau Sands Theatre.

2017

Got G-mark Design Award; Launched commercial fine pixel pitch products for the first time; Founded US & Netherland subsidiary.

2018

First year for IPO and launched listing plan officially; Launched the independent SRG technology.

2019

Established Dicolor Dongguan Intelligent Co., Ltd with 21,000m²; HP & HT series Got Red Dot Design award; Founded Russian Subsidiary and Malaysia branch office.

**INTERNATIONAL
MARKETING NETWORK**

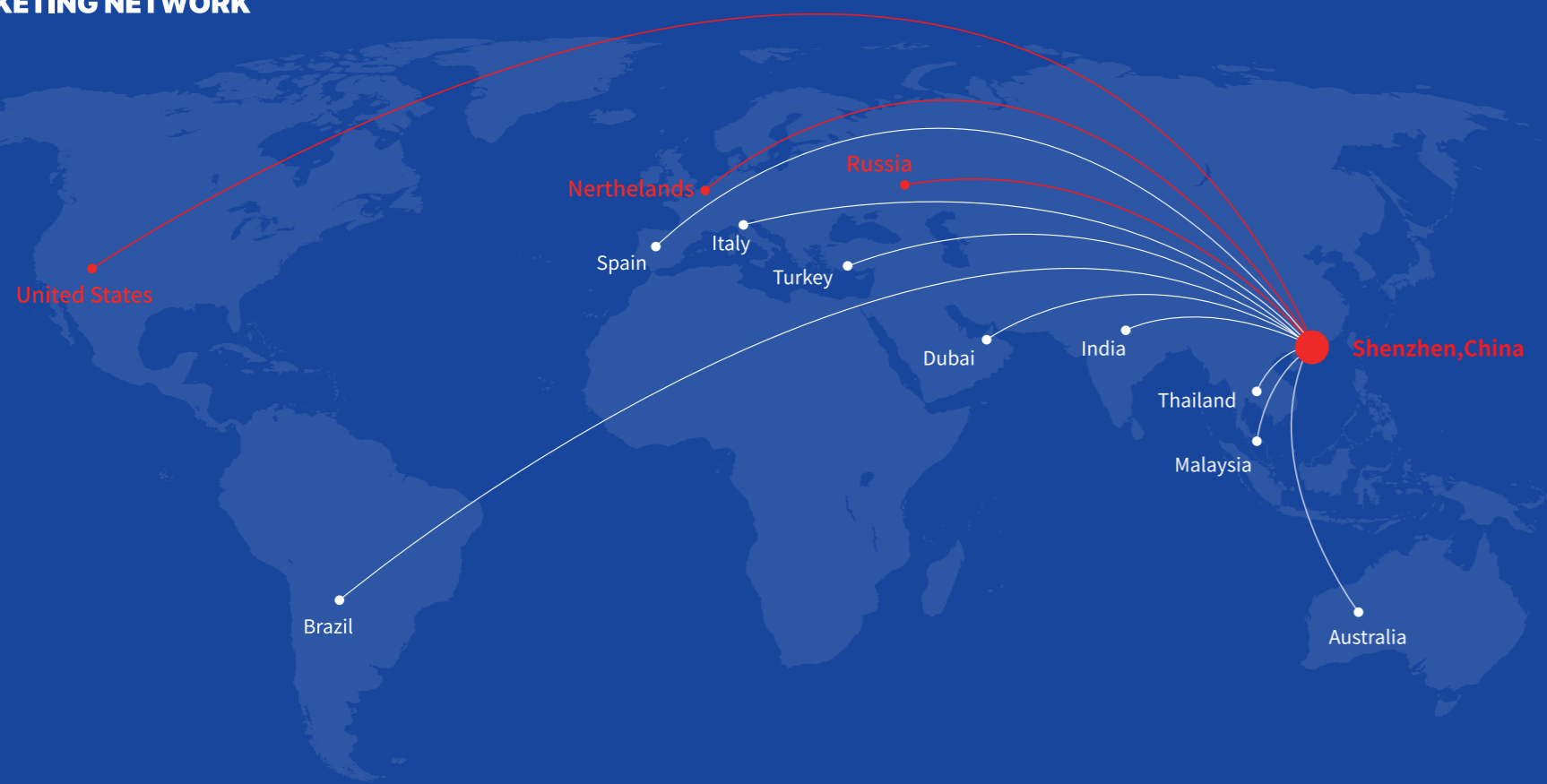

DICOLOR USA INC.
3550 E Post Rd, Suite 400 Las Vegas, NV 89120



DICOLOR B.V.
Esp 112A, 5633AA Eindhoven, Netherlands



ООО Диколор
127015, г. Москва, ул. Новодмитровская, д. 5А, стр. 1; Этаж: 11; Офис: 1106

**DOMESTIC
MARKETING NETWORK**



- Headquarters
- Branch office
- Channel partner

HONORS & CERTIFICATIONS



National Hi-Tech Enterprises



Excellent enterprise of display screen



The Most Growing Company of LED Industry in China



Contract and Trustworthy Enterprise of Guangdong province



Recommended Brands for Smart City Construction in 2019



AAA credit rated enterprise



Red dot award



China good design award



Japan Good Design Award



2019 Security Top Ten Outstanding Product Awards

HONORS & CERTIFICATIONS



ISO4001 Environment management system



Intellectual Property Management System



China Energy Conservation Certificate

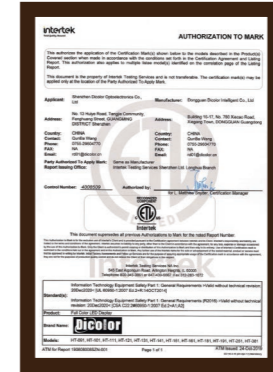

ETL Certification



3C Certification



RoHS Certification



CE Certification



FCC Certification



Computer Software Copyright



Appearance Design Patent Certification

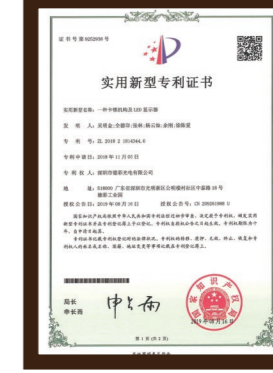

Utility Model Patent Certification



Invention Patent

CORE TECHNOLOGY

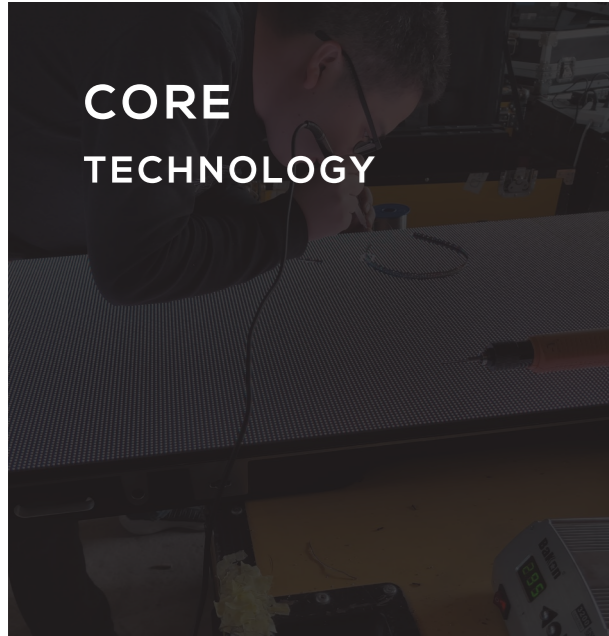

D-COB TECHNOLOGY



(Double Chip on Board) A secondary packaging technology based on Mini/Micro LED developed by Dicolor, which effectively protects the substrate and LED packaging unit. It can resist against extremely harsh environment, and achieve true waterproof, dust-proof, anti-corrosion, anti-static, anti-collision, and Anti-UV. The consistency, protection class and stability are significantly improved. D-COB can be widely used in Ultra HD Display areas.

SRG TECHNOLOGY



Super refresh rate and gray level, based on the general application software, combined with Dicolor self-developed functional chips, this technology can improve refresh rate, gray level and contrast to a large extent. SRG technology is a great breakthrough in display technology of Dicolor.

ABR TECHNOLOGY



Anti-collision Bottom Reinforcement Technology, used to increase the adhesion between the LED pins and the PCBs on both sides of the LED lamp pins, which greatly improves the problem of LED bumping and falling during production and customer use, effectively protect the LED lamps on the edge and reduce maintenance cost.

6G NEAR FIELD WIRELESS TRANSMISSION TECHNOLOGY



A non-contact electromagnetic wave signal propagation technology, by adding an electromagnetic wave sensor to the module and the HUB board, which can free the module from the restriction of the signal cable and make the signal transmission more stable, reduce the problems of false soldering and poor contact in the conventional pin header. The stability of the module is largely improved.

FAST-LOCK KNOB



A knob-type structure can quickly realize multiple splicing angles. Each rotating surface has an angled boss. The angle boss is die-cast and has ultra-high precision. By rotating and replacing the boss can effectively reduce the precision difference caused by changing the height of the boss. We can quickly realize high-precision arc splicing.

Brand Is Based On Quality

Dicolor has a complete set of quality control system from raw materials, manufacturing process, and delivery to ensure that customers' quality expectations are met.

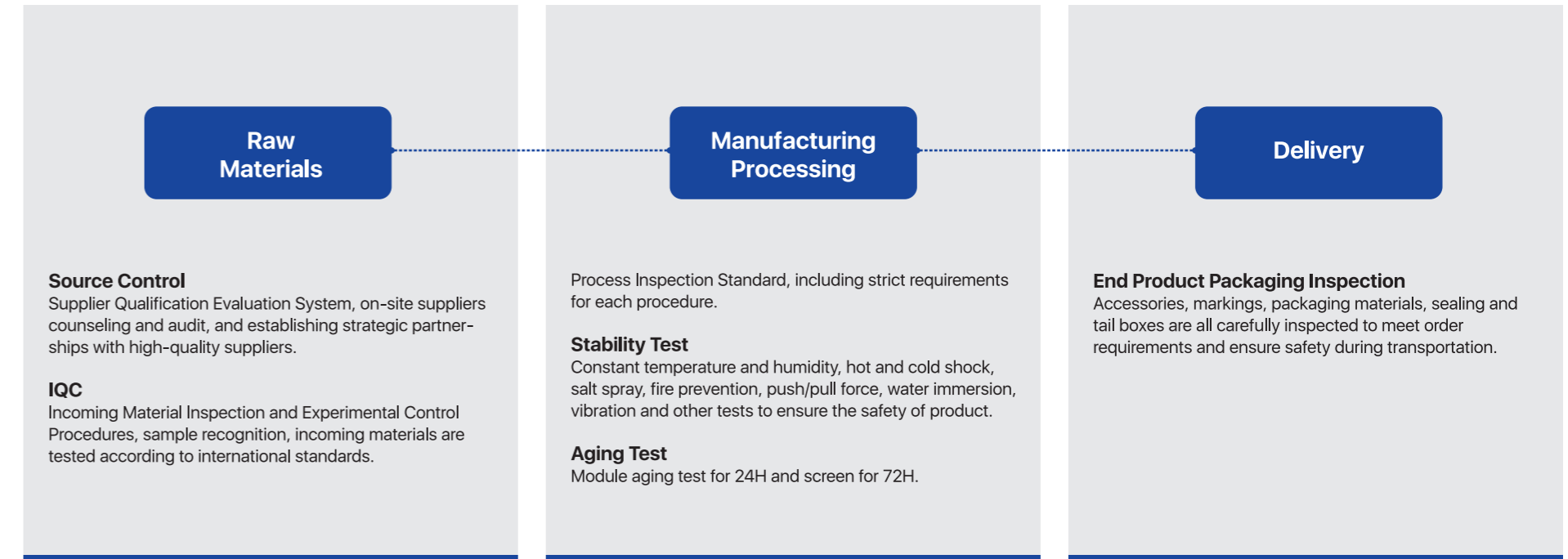



HDC SERIES

- Higher Stability
Waterproof
Dustproof
Anticorrosion
Antioxidant
Anti-static
- High Protective
Anti-knock
Anti-vibrating
Hard-wearing
- Excellent Rendering
Lower Glare
Pastel-colored
Wider Angle
- Good Heat Dissipation
Short Path
Large Cooling Area

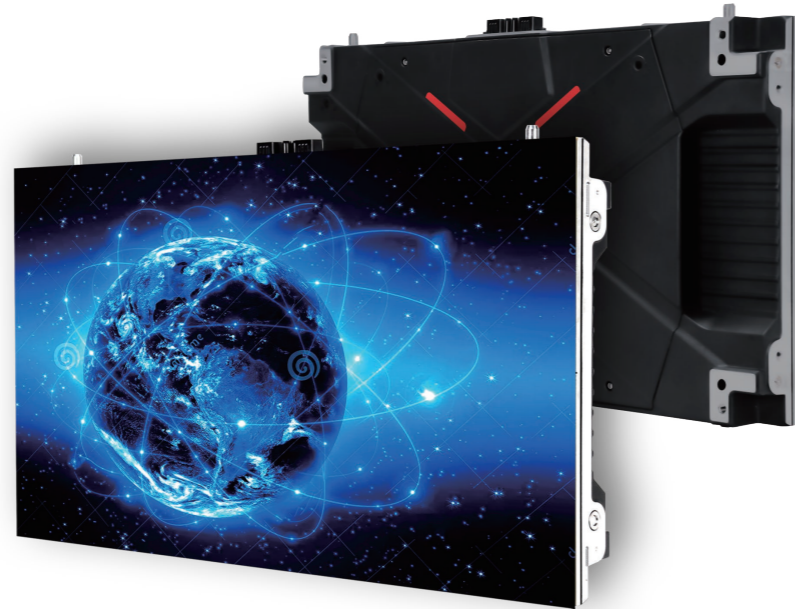

Product	HDC-091	HDC-121	HDC-151
Pixel Pitch (mm)	0.9375	1.25	1.5625
Pixel Type	D-COB Integrated Packaging	D-COB Integrated Packaging	D-COB Integrated Packaging
Cabinet size (W×H×D/mm)	600×337.5×74	600×337.5×74	600×337.5×74
Cabinet Resolution	640×360	480×270	384×216
Cabinet Weight (Kg)	8.46	8.0	8.0
Brightness (Nits)	400 Option	400 Option	400 Option
Refresh Rate (Hz)	≥3840	≥3840	≥3840
Gray Scale (Bit)	14	14	14
IP Rating (Front/Rear)	IP54/IP21	IP54/IP21	IP54/IP21
Max./Avg Power Consumption (W/m ²)	600/200	600/200	600/200

Higher Stability

Compared to traditional COB encapsulation technology, Dicolor unique D-COB secondary encapsulation technology improves a lot product reliability from the encapsulation process and manufacturing process. Except Convenient touch and smart writing function, it also can be wiped and cleaned directly. D-COB effectively protect it from bumping and dropping lights or even pad falling down during transportation and installation, which will help reducing user maintenance costs.

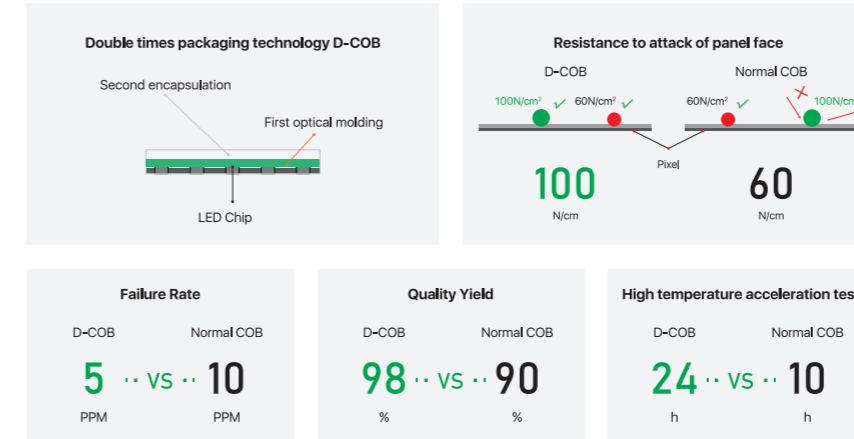

Higher Protective

D-COB is effectively anti-static, anti-corrosion, anti-oxidation, compared with SMD discrete devices and common COB, the dead lamp rate is lower and the lifespan is longer. users do not worry about high temperature and humidity storage, transportation and operation environment

- Waterproof
- Dustproof
- Anticorrosion
- Antioxidant
- Antistatic



Wide Color Gamut

With RGB tricolor imaging technique, it has 115% NTSC, 281 trillion colors, and by surface reflective treatment, this product has good light directivity and less surface glare, colors are richer and more delicate. The horizontal and vertical viewing angle is 170° /170°.

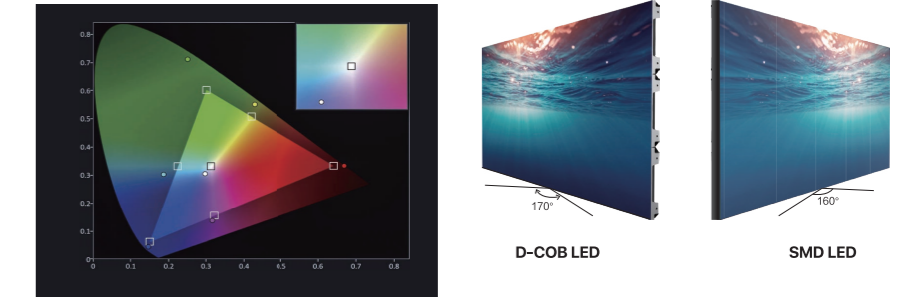

Good Heat Dissipation And Common Cathode

The positive and negative electrode of the LED chip in the D-COB is directly connected to the circuit on the PCB, with the shortest heat conduction path, no intermediate medium, the minimum thermal resistance, better heat dissipation effect than SMD discrete devices, and better Full Front power saving effect.

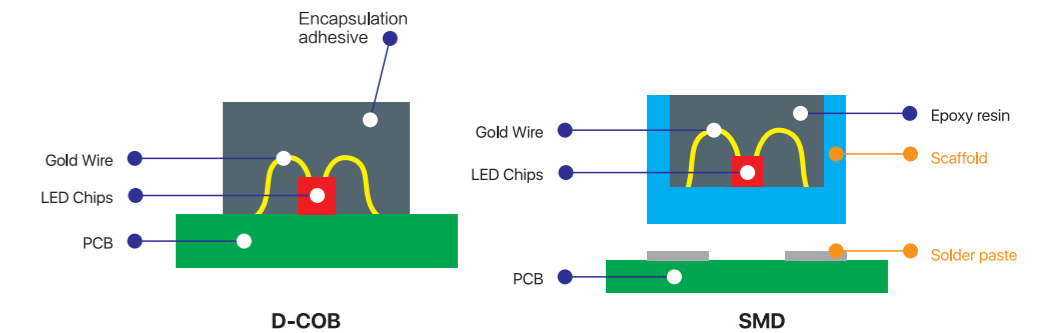



HA SERIES

- Extremely Light & Slim
- Wireless Connection
- Full Front Maintenance
- Dual-Backup
- High Grey Level And Refresh Rate
- 16:9 Ratio
- 2K/4K Standard Resolution

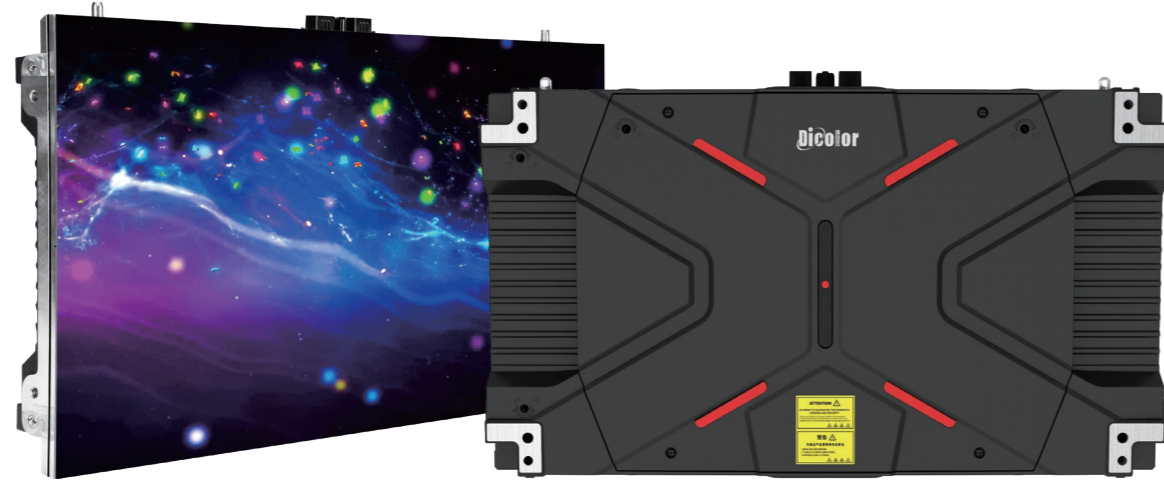

Product	HA-091	HA-121	HA-151	HA-181
Pixel Pitch (mm)	0.9375	1.25	1.5625	1.875
Cabinet size (W×H×D/mm)	600×337.5×57	600×337.5×57	600×337.5×57	600×337.5×57
Cabinet Resolution	640×360	480×270	384×216	320×180
Cabinet Weight (Kg)	6.5	6.5	6.5	6.5
Brightness (Nits)	600	600	600	800
Refresh Rate (Hz)	≥3840	≥3840	≥3840	≥3840
Gray Scale (Bit)	16	14	14	14
IP Rating (Front/Rear)	IP40/IP21	IP40/IP21	IP40/IP21	IP40/IP21
Max./Avg Power Consumption (W/m²)	730/209	780/260	690/231	750/250

High Gray Level, High Refresh Rate, Perfect Display

Low brightness with high gray level and high refresh rate, stable dynamic display effect, no ripple, no flicker, the edge of the image is clear, and the visual experience is more comfortable.



HD Seamless Display

HD Seamless Display, eliminate the visual seam, and enjoy the big and complete display effect.



LED Display

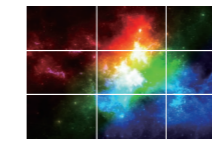

DLP Splicing

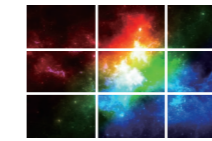

LCD Splicing

Easy Maintenance

Available for installation on the wall, full front maintenance for the modules, receiving cards, and power suppliers, support multiple installation methods.

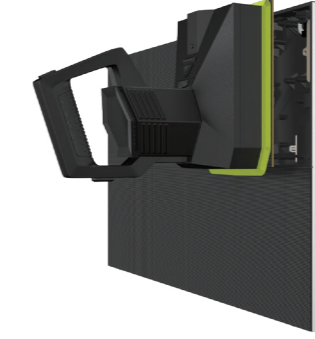

Extremely Light And Slim

Adopt die-casting modular design, 16:9 ratio design, cabinet width only 57 mm, saving the installation space and edge covering cost.

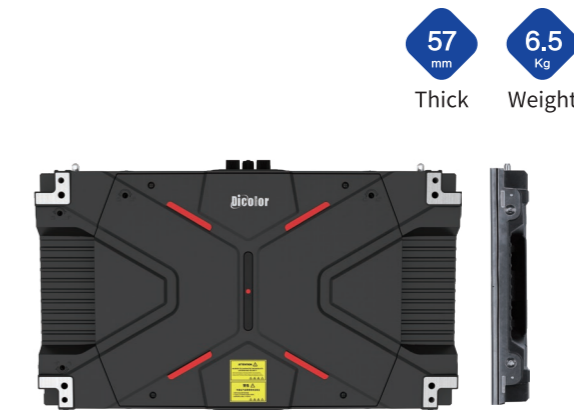

Dual-backup Design

Dual-backup design of the power and signal, making the fine pixel products more steady and reliable.

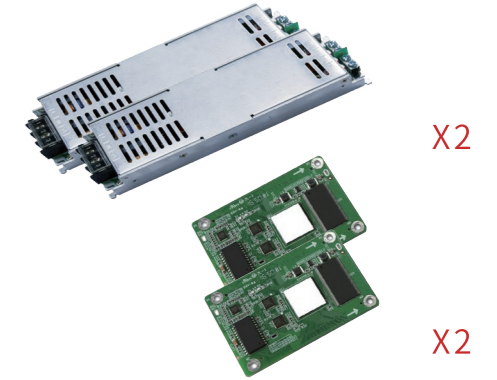

Wireless Connection

Wireless connection technology and port backup function, reducing the wire connection between the cabinets, to save time and cost.

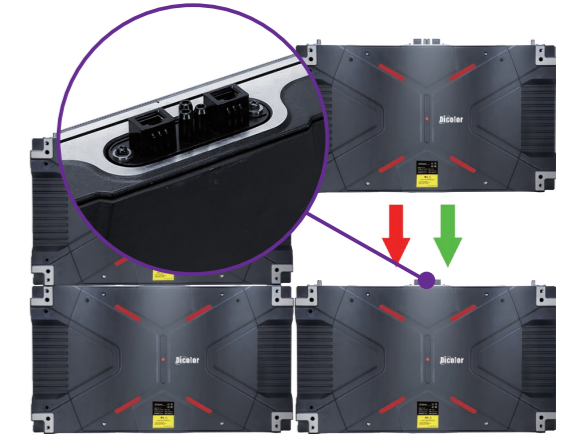



HP SERIES

- HD**
High Definition
- 8**
Seamless Splicing
- ⌚**
Long Lifespan
- =**
Good Flatness
- 🔥**
Good Heat Dissipation
- 👁️**
Wide Viewing Angle
- Hz**
High Grey Level And Refresh Rate
- ⚙️**
Front Maintenance

Product	HP-121	HP-161	HP-181	HP-251
Pixel Pitch (mm)	1.25	1.667	1.875	2.5
Cabinet size (WxHxD/mm)	480×480×65	480×480×65	480×480×65	480×480×65
Cabinet Resolution	384 x 384	288 x 288	256 x 256	192 x 192
Cabinet Weight (Kg)	6.7	6.7	6.7	6.7
Brightness (Nits)	600(Adjust)	600(Adjust)	800(Adjust)	800(Adjust)
Refresh Rate (Hz)	≥2880	≥2880	≥2880	≥2880
Gray Scale (Bit)	14	14	14	14
IP Rating (Front/Rear)	IP40/IP21	IP40/IP21	IP40/IP21	IP40/IP21
Max./Avg Power Consumption (W/m²)	650/217	630/210	600/200	420/140

HD Seamless Display

HD seamless display, enjoy the big and complete display effect.

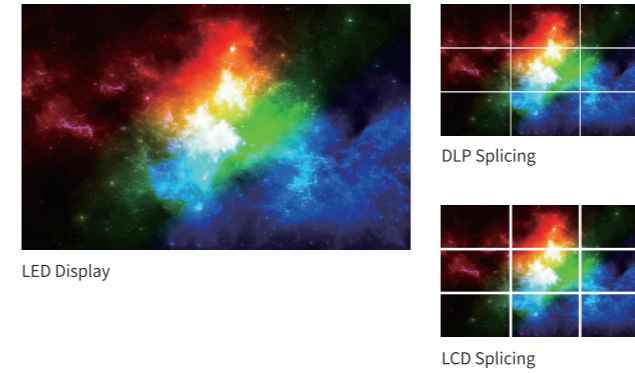

High Grey Level And High Refresh Rate

Low brightness with high grey level and high refresh rate, stable dynamic display effect, no ripple, no flicker, the edge of the image is clear, and the visual experience is more comfortable.



Response In Nanoseconds

Frames change in nanoseconds, fast dynamic display without ghosting and tailing.



Extra Wide Viewing Angle

Extra wide viewing angle, no blind angle and color cast.

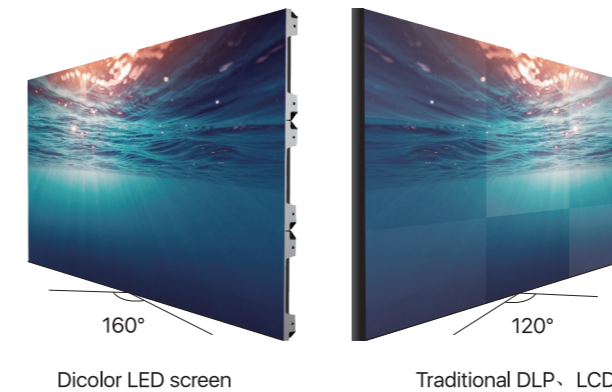

Die Cast Aluminum Cabinet

Die cast aluminum cabinet, special heat dissipation design, ensure stable and safety performance.

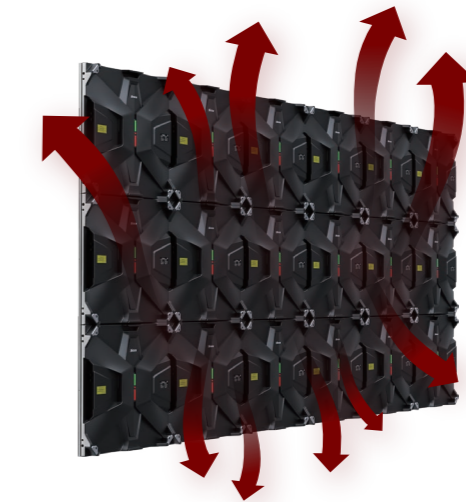

Easy Installation And Maintenance

Easy installation and maintenance, support module front maintenance, multiple installation options like staking, bracket mounting, etc. (power and signal dual-backup function is available).

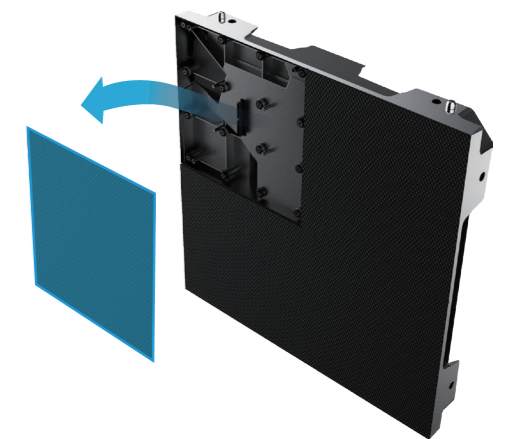

PRODUCTS CENTER



HT SERIES

- High Definition
- Wireless Connection
- Extremely Light & Slim
- Full Front Maintenance
- 16:9 Ratio
- Dual-Backup
- Rectangular Splicing
- 2K/4K Standard Resolution



Product	HT-121	HT-131	HT-151	HT-191
Pixel Pitch (mm)	1.267	1.357	1.583	1.9
Cabinet size (W×H×D/mm)	608×342×62	608×342×62	608×342×62	608×342×62
Cabinet Resolution	480×270	448×252	384×216	320×180
Cabinet Weight (Kg)	6.2	6.2	6.2	6.2
Brightness (Nits)	600	600	600	800
Refresh Rate (Hz)	≥2880	≥2880	≥2880	≥2880
Gray Scale (Bit)	14	14	14	14
IP Rating (Front/Rear)	IP40/IP21	IP40/IP21	IP40/IP21	IP40/IP21
Max./Avg Power Consumption (W/m ²)	780/260	770/257	692/231	730/240
Curve	90 °	90 °	90 °	90 °

High Grey Level High Refresh Rate Perfect Display

Low brightness with high grey level and high refresh rate, stable dynamic display effect, no ripple, no flicker, the edge of the image is clear, and the visual experience is more comfortable.



Wireless Connection

Wireless connection technology and port backup function, reducing the wire connection between the cabinets, to save time and cost.

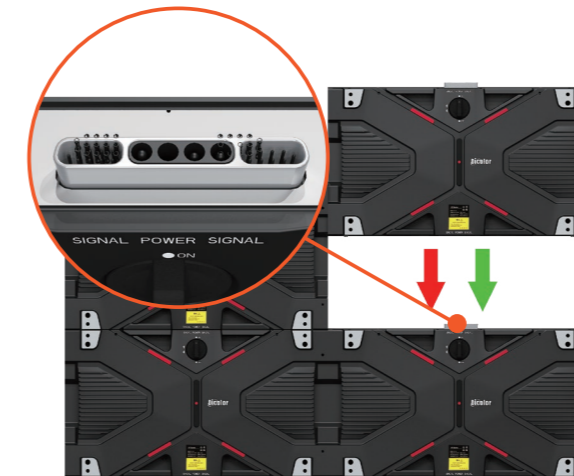

Easy Maintenance

Available for installation on the wall, full front maintenance for the modules, receiving cards, and power suppliers, easy installation and maintenance.

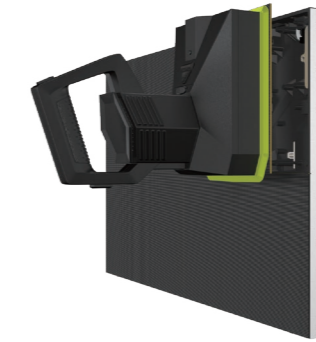

Extremely Light and Slim

Adopt die-casting modular design, 16:9 ratio design, installation width only 60 mm, leading in this industry, saving the installation space and edge covering cost.



Dual-backup Design

Dual-backup design of the power and signal, making the fine pixel products more steady and reliable.

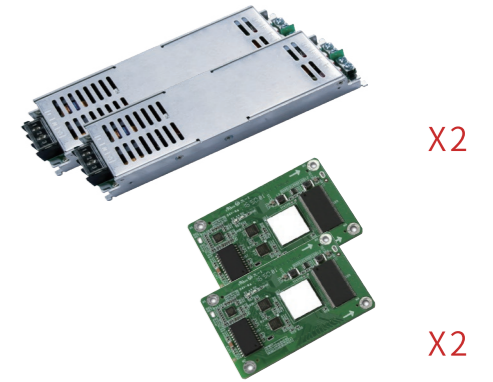

90° Rectangular Splicing

Rectangular splicing is available, structural fine-tuning technology, ensuring the flatness when splicing, seamless splicing, to solve the industry accuracy difficulty in splicing of fine pixel products. Coupler locks embedded inside four sides of the cabinets, making the installation easier and more convenient, saving the time and labor.

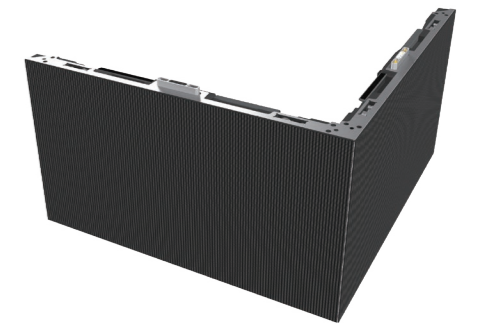



MS SERIES

- Front Maintenance
- Rectangular Splicing
- Multi Functional
- Curve Design
- Extremely Light & Slim



Product	MS-191	MS-261	MS-291	MS-391
Pixel Pitch (mm)	1.953	2.604	2.97	3.91
Cabinet size (WxHxD/mm)	500x500x62	500x500x62	500x500x62	500x500x62
Cabinet Resolution	256x256	192x192	168x168	128x128
Cabinet Weight (Kg)	5.8	5.8	5.8	5.8
Brightness (Nits)	800	800	800	800
Refresh Rate (Hz)	≥2800	≥2800	≥3840	≥3840
Gray Scale (Bit)	14	14	14	14
IP Rating (Front/Rear)	IP40 / IP21	IP40 / IP21	IP40 / IP21	IP40 / IP21
Max./Avg Power Consumption (W/m ²)	520 / 147	520 / 147	520 / 147	520 / 147
Curve	90°	90°	90°	90°

Extremely light weight and thin thickness

Thickness less than 62mm, weight in 6kg, ahead of other suppliers.

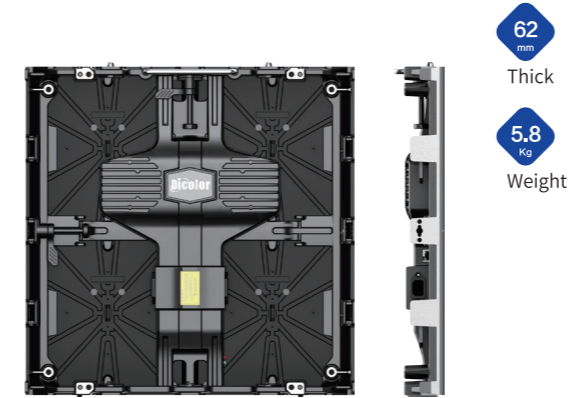

Front Maintenance

Modules and power receiving cards can be removed from the front.

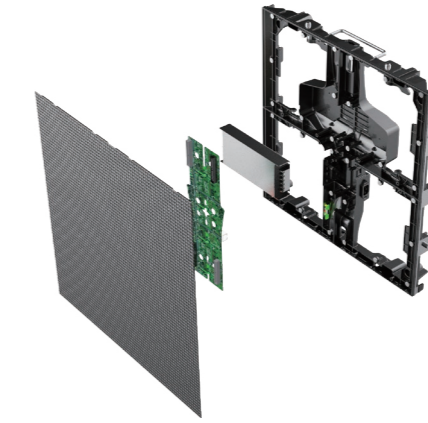

90° Rectangular Splicing

Supports 0 ~ 90° custom angles, can be made at 90° angle splicing.

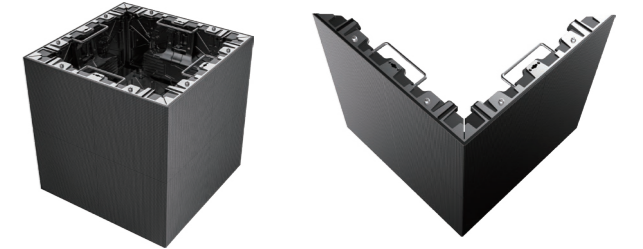

Multi-purpose with 1set screen

Support fixed use, but also compatible with rental use.

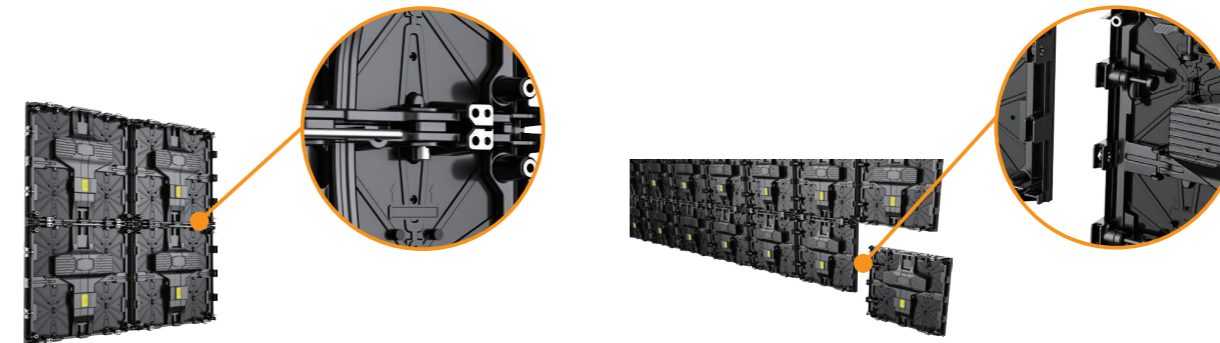

Ultra-thin installation

Using mounting bracket can be wall mounting.

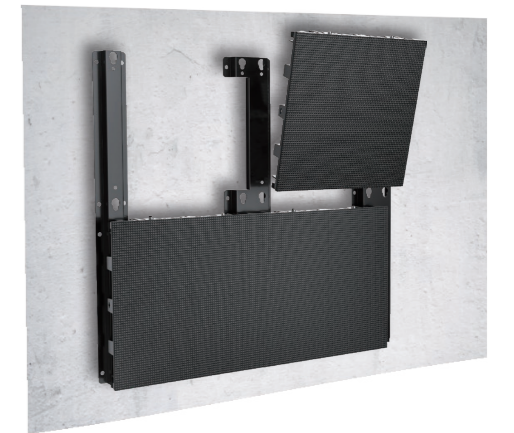



MS OUTDOOR

- Fast assembling
- Long lifespan
- Front maintenance
- Good heat dissipation
- Standard
- Concise
- Rectangular splicing
- Safety

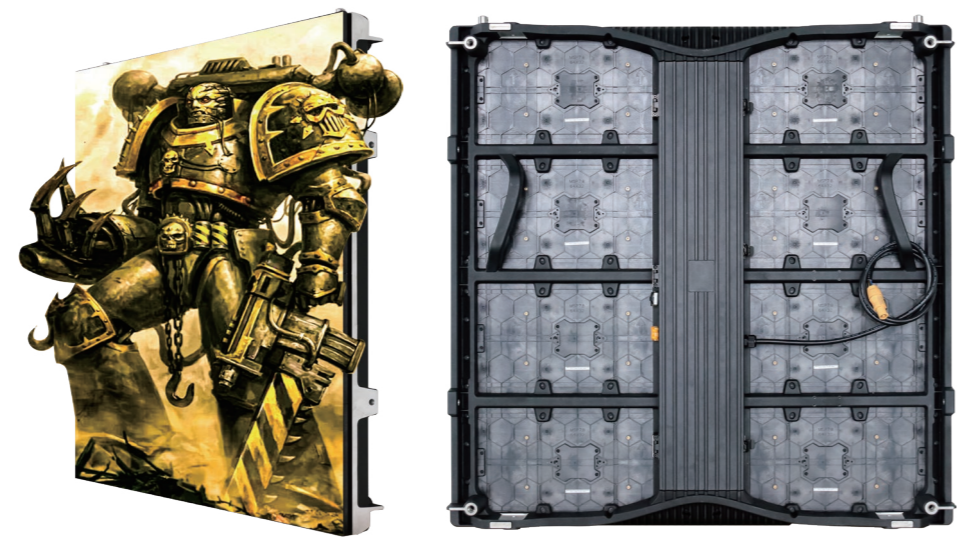

Product	MS-480	MS-780	MS-100
Pixel Pitch (mm)	4.81	7.81	10.41
Cabinet size (W×H×D/mm)	1000×1000×100	1000×1000×100	1000×1000×100
Cabinet Resolution	208×208	128×128	96×96
Cabinet Weight (Kg)	30	30	30
Brightness (Nits)	4500	6500	7000
Refresh Rate (Hz)	1920	1920	1920
Gray Scale (Bit)	14	14	14
IP Rating (Front/Rear)	IP65 / IP54	IP65 / IP54	IP65 / IP54
Max./Avg Power Consumption (W/m ²)	720 / 240	680 / 226	570 / 190

Standard

Single cabinet size is a standard size of one square meter, reduce transportation and installation costs.



Precision

The cabinet is integrally molded using die-casting material, anti-deformation module kit, have higher precision.

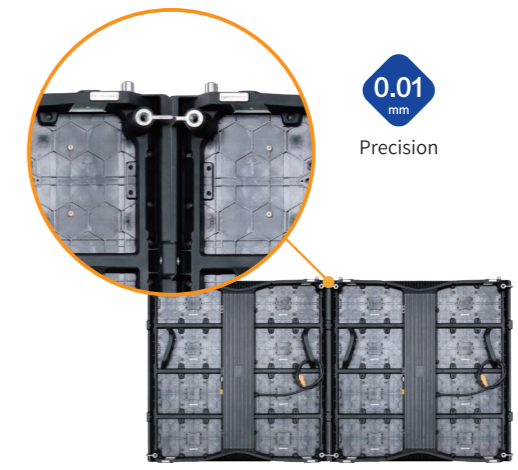

Share

Same cabinet for different pixel pitch to achieve universal switch.



90° Splicing

Optional beveled cabinet, support 90° right-angle stitching.



Convenient

Full front maintenance design, module, power, receiving card can be maintained from the front, power and signal cables were fixed on cabinet already, convenient and fast.



Naked Installation

Die-cast aluminum cabinet, good heat dissipation, no air conditioner, no edging, saving steel structure.





HM SERIES

- Light & Slim
- Intelligent
- Front Maintenance
- Convenient Installation

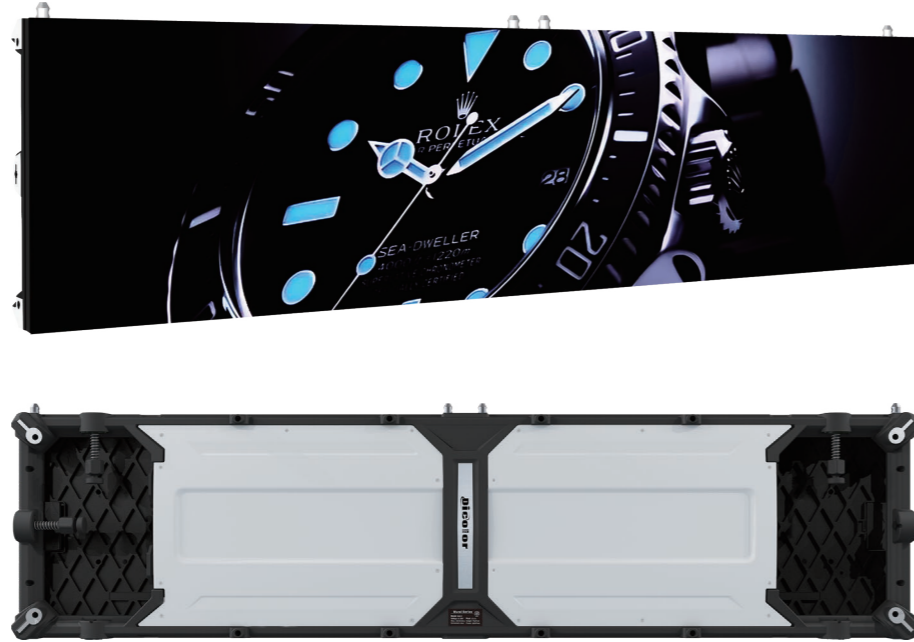

Product	HM-2		HM-3		HM-4		HM-4A	
Pixel Pitch (mm)	2.5		3.125		4		4	
Cabinet size (W×H×D/mm)	600×300×47	1200×300×47	600×300×47	1200×300×47	600×300×47	1200×300×47	600×300×60	1200×300×60
Cabinet Resolution	240×120	480×120	192×96	384×96	150×75	300×75	150×75	300×75
Cabinet Weight (Kg)	5 / 10		5 / 10		5 / 11		6 / 10	
Brightness (Nits)	800		800		800		4000	
Refresh Rate (Hz)	≥2880		≥2880		≥2880		≥1920	
Gray Scale (Bit)	14		14		14		14	
IP Rating (Front/Rear)	IP40/IP21		IP40/IP21		IP40/IP21		IP40/IP21	
Max./Avg Power Consumption(W/m²)	462/154		445/149		445/149		600/200	

Light and slim

Cabinet thickness only 47mm, panel weight 10KG, super light and slim, good for installation and transportation.

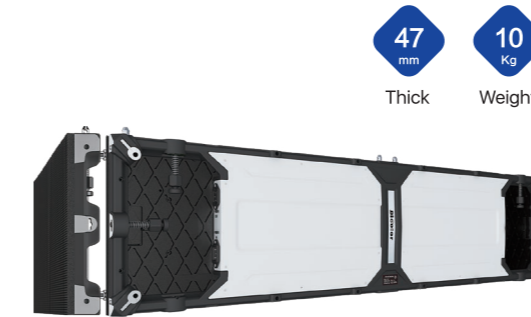

Convenient installations

Can be installed on the wall, saving space. Two in one installation bar, fast and easy to operate hanging installation, stacking installation, front installation and other installations are available.

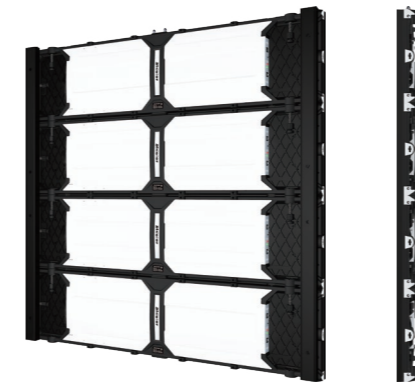

Intelligent

Intelligent cloud group control. One network equipment can do the management and monitoring of all screens.

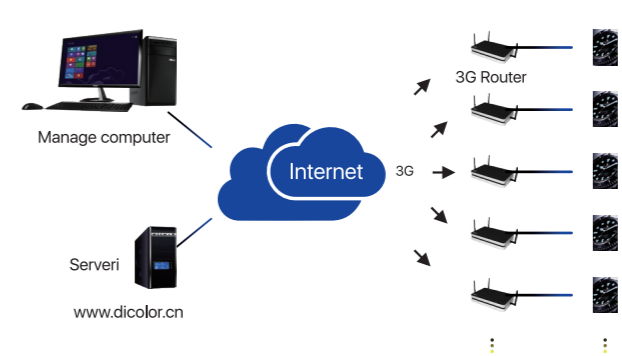

Size selection

Selection of various cabinet dimensions.

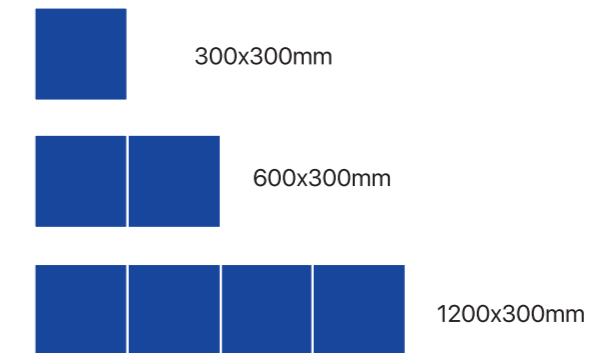

Front Maintenance

Full front service modules, power supplies, and receiving card can be maintained from the front.

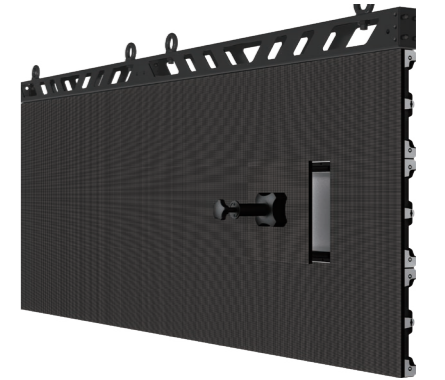

90° Rectangular Splicing

300x300 cabinet can be fitted with 90 degree right angle splicing function.



PRODUCTS CENTER



All-in-one Smart Solution

5 Core Technology

- D-COB** Unique Technology
- AIO** Equipment Integration
- CRMT** Color Refinement Management Technology
- AI** AI Application
- Slim & Light**

4 Applications

- Intelligent Writing**
Smooth writing and fast response
- File Management**
Document, picture, audio, video presentation
- Wireless Screen Transmission**
Multi-screen interaction, support 4 split screen simultaneous casting
- Online Meeting**
Remote online meeting, efficient communication



D-cob Double Times Packaging Technology

Compared to traditional COB encapsulation technology, DICOLOR unique D-COB secondary encapsulation technology improves a lot product reliability from the encapsulation process and manufacturing process. makes touch/control more sensitive, higher stability, higher protection level, speed cleaning, maintenance cost saving.



All-In-One Equipment

Improve efficiency and ease of use by highly integrated with traditional distributed projection, controlling computers, electronic whiteboards, projection screens and audio devices. By the way, one-button online, wireless access devotes to fast and convenient operation.



AI application

Support multi-device conference desktop information sharing and collaboration, conference annotation, sensitive touch and electronic whiteboard writing to realize conference paperless management.

Ai Face Recognition

- Intelligent identification, marking the identity information of participants
- Image recognition, automatic analysis of attendance statistics

Smart Voice Translate

- Automatic voice to text, and save as meeting minutes
- Voice translation is automatically recognized and displayed through subtitles

More Screen Share

- Support wireless screen and electronic writing, environmental efficiency
- Any multi - conference terminal access, desktop sharing

Color Refinement Management Technology

Point-to-point calibration can be achieved within the resolution of 2K, and it can reach 18bit by coordination of fine radian algorithm and hardware ; Maximum 218 trillion colors devoted by high precision light gun calibration gamut, which let the color quantitative display, it's higher than 115% of the NTSC broadcast gamut range.

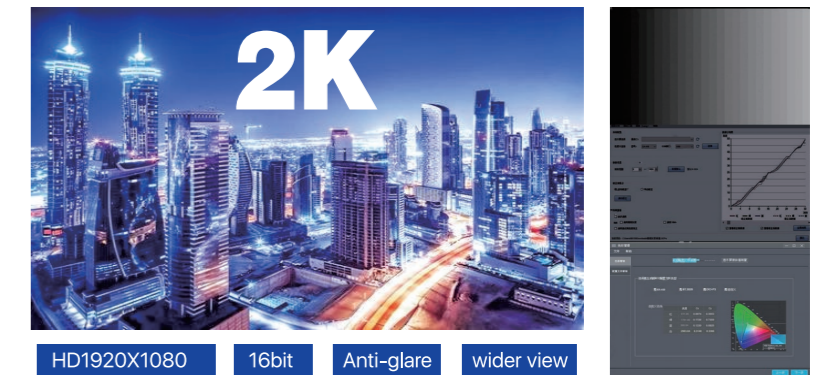

Melink-HA Series (LED)

Product Model	Melink-HA108	Melink-HA135	Melink-HA162	Melink-HA108C	Melink-HA135C	Melink-HA162C
Display Size (inch)	108	135	162	108	135	162
Overall Dimension(W×H×D)/mm	2454×1472×82	3054×1810×82	3654×2147×82	2454×1472×90	3054×1810×90	3654×2147×90
Pixel Pitch (mm)	1.25	1.5625	1.875	1.25	1.5625	1.875
Pixel Configuration	SMD1010	SMD1010	SMD1415	D-COB	D-COB	D-COB
Resolution	1920×1080 (16:9, 2K)					
Refresh Rate (Hz)	≥3880Hz	≥3880Hz	≥3880Hz	≥3880Hz	≥3880Hz	≥3880Hz
Brightness After Correction(Nit)	400 (adjustable)	400 (adjustable)	400 (adjustable)	400 (adjustable)	400 (adjustable)	400 (adjustable)
Color Depth (Bit)	16					
Frame Material	Aluminum profile					
Net Weight (Kg)	124	187	263	128	194	274
Installation	Mobile bracket, Wall mounting, Lifting, Seat mounting (choose 1 from 4)					
Maximum Power (Kw)	1.6	2.4	2.7	1.7	2.6	3.0
System Interface	Support Windows and Android switching					
Supported Formats	Picture: .jpg / .bmp, .png; Video: avi / mpg / vob / mov / mkv / rmvb / mp4 / ts / flv					
Touch System	Not support	Not support	Not support	Infrared touch / ≤10ms / standard 10 points / USB power supply, 5V / 400mA		

Melink-HX Series (LED)

Product Model	Melink-HX108	Melink-HX135	Melink-HX162	Melink-HX108C	Melink-HX135C	Melink-HX162C
Display Size (inch)	108	135	162	108	135	162
Overall Dimension(W×H×D)/mm	2440×1428×30	3040×1766×30	3640×2103×30	2440×1428×38	3040×1766×38	3640×2103×38
Pixel Pitch (mm)	1.25	1.5625	1.875	1.25	1.5625	1.875
Pixel Configuration	SMD1010	SMD1010	SMD1415	D-COB	D-COB	D-COB
Resolution	1920×1080 (16:9, 2K)					
Refresh Rate (Hz)	≥3840Hz	≥3840Hz	≥3840Hz	≥3840Hz	≥3840Hz	≥3840Hz
Brightness After Correction(Nit)	400 (adjustable)	400 (adjustable)	400 (adjustable)	400 (adjustable)	400 (adjustable)	400 (adjustable)
Color Depth (Bit)	16					
Frame Material	Aluminum profile					
Net Weight (Kg)	109	159	221	114	167	245
Installation	Mobile bracket, Wall mounting, Lifting, Seat mounting (choose 1 from 4)					
Maximum Power (Kw)	1.6	2.4	2.7	1.7	2.6	3.0
System Interface	Support Windows and Android switching					
Supported Formats	Picture: .jpg / .bmp, .png; Video: avi / mpg / vob / mov / mkv / rmvb / mp4 / ts / flv					
Touch System	Not support	Not support	Not support	Infrared touch / ≤10ms / standard 10 points / USB power supply, 5V / 400mA		

DICOLOR BEST CASES



Uzbek National Security Agency



French TV



University of Cambridge, UK



Korean church LED Display



Yan'an Art Museum



South Building of China Railway Construction Group, Shenzhen



Bangkok Chinese Federation of Trade Unions



At the Lao International Convention Center



Inner Mongolia Civil Air Defense



A Traffic Mangement Bureau in Shanghai



Moscow Sheremetyevo International Airport



Madrid Airport

**DICOLOR
BEST CASES**



Manila Airport, Philippines



RATINA Shopping Plaza in Tampere, Finland



BURBERRY, Russia



Conference screen in Peru

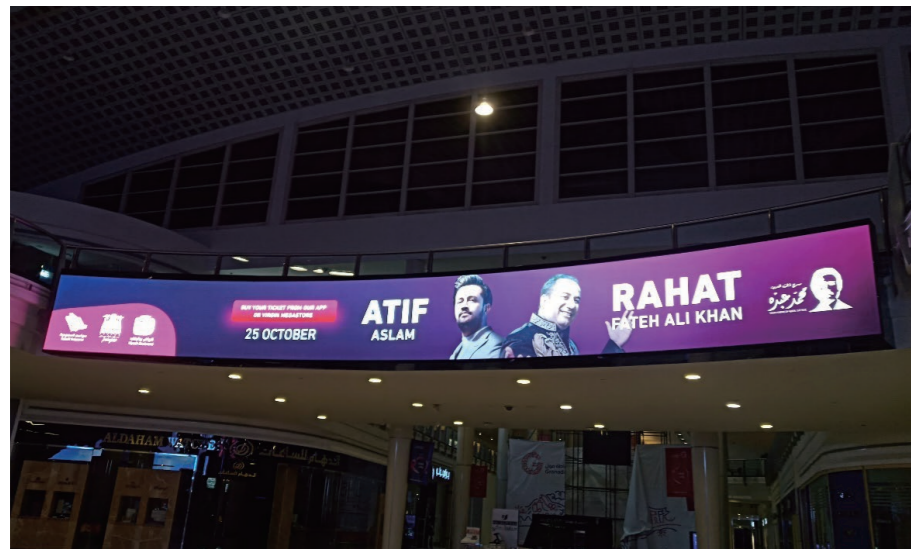

Riyadh Garanada Mall & Hayat



Jarvis Convention Center, New York, USA



CEV Volleyball European Championship 2017



Swimming competition case in Sweden

**DICOLOR
BEST CASES**

**DICOLOR
BEST CASES**



Philippine outdoor advertising screen



German Formula One Competition



A sport bar in USA



Rio Olympics



Malaysian lamppost screen



Outdoor double-sided advertising big screen in Nigeria



Columbia Church LED Display



Russian Channel one



Macao Jinsha Grand Theatre



Trade and Investment Fair of South and Southeast Asian countries



Night of black Valley in Shandong Province



Concert in Sao Paulo, Brazil

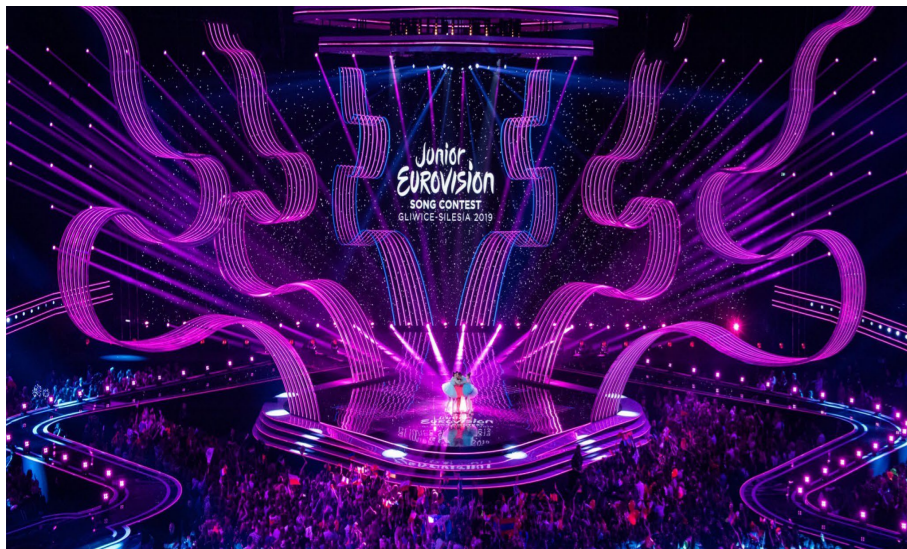

Eurovision contest event in Poland



American 311 concert tour



Sopot Music Festival in Poland



Turkish presidential campaign